

Bird Feeder

YellaWood
Pressure Treated Pine

This bird feeder should attract many different birds to your yard. With a platform for those birds that like to move around on a flat surface while they pick at feed as well as a dowel for those who prefer a more natural "perch," this project will please both people and fowl for years.

The roof is removable for easy filling and the sub-base, with screen and drainage holes, will keep the seed from soaking up moisture, which will keep your backyard friends happier and healthier.

BUILD TIME

Cutting parts: 2 hours

Assembly: 1 hour

Finishing: 2 hours

Total: 5 hours

*Note: Drill $\frac{1}{8}$ " pilot holes for all screws

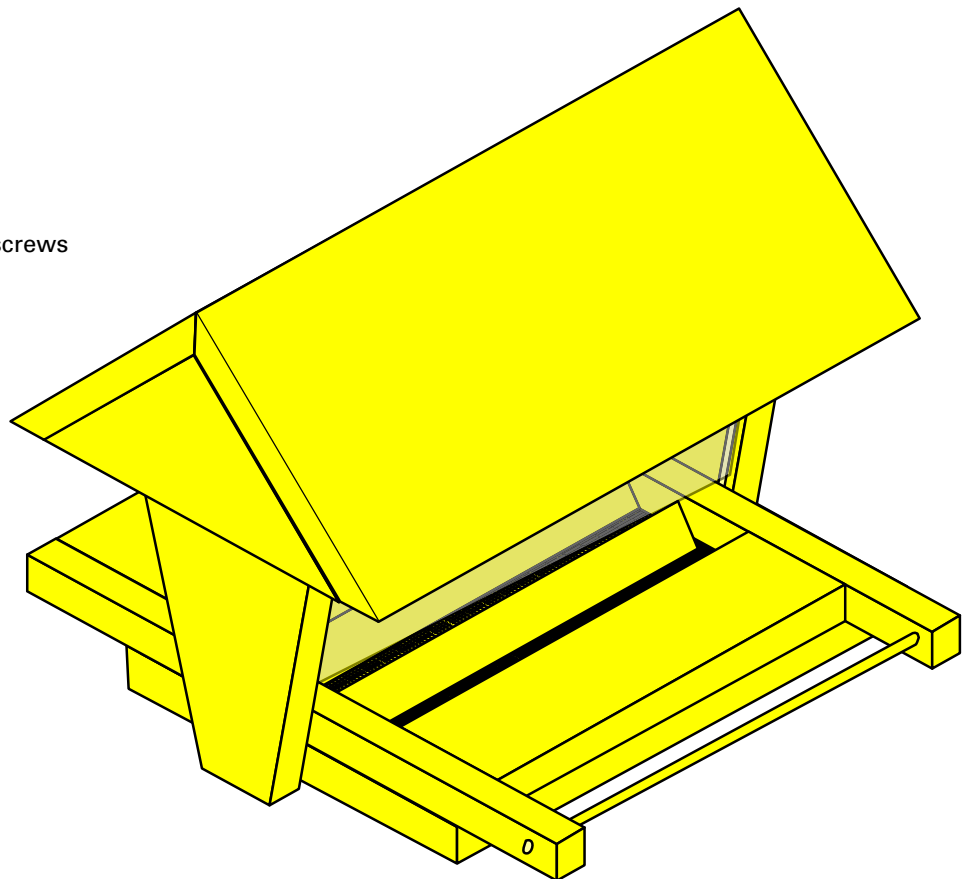

Bird Feeder

YellaWood
Pressure Treated Pine

TOOLS

Miter saw
Table saw
Drill/driver
1/8" drill bit
5/16" drill bit
1/2" drill bit
Brad nailer
Utility knife
Square
Metal cutting snips
Staple gun
Clamps
Damp rag to wipe up excess glue
Paint/Stain Brush

SUPPLIES

(2) 1 x 8 x 8'
(2) 1/8" x 5 1/2" x 13 1/2" acrylic sheets 1/4"
by 13" dowel
5" x 10" metal screen
Waterproof wood glue
YellaWood Protector® Stain & Sealer
3/4" galvanized brads
1 1/4" galvanized brads
3/8" galvanized staples
1 1/4" deck screws

CUT LIST

A	(1)	3/4 x 7 1/4 x 9"
B	(2)	3/4 x 1 x 17 3/4"
C	(1)	3/4 x 3 1/2 x 11"
D	(1)	3/4 x 9 x 11"
E	(1)	3/4 x 1 1/2 x 11"
F	(2)	3/4 x 5 1/2 x 10"
G	(2)	3/4 x 4 x 8"
H	(2)	3/4 x 7 1/4 x 16 1/2"
I	(1)	3/4 x 3/4 x 13"
J	(1)	3/4 x 5 x 8"
K	(2)	3/4 x 3/4 x 5"
L	(1)	1/4 x 12 1/2"

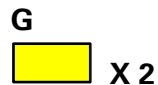
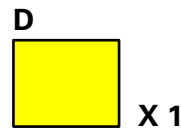
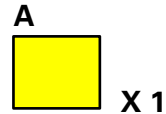

Bird Feeder

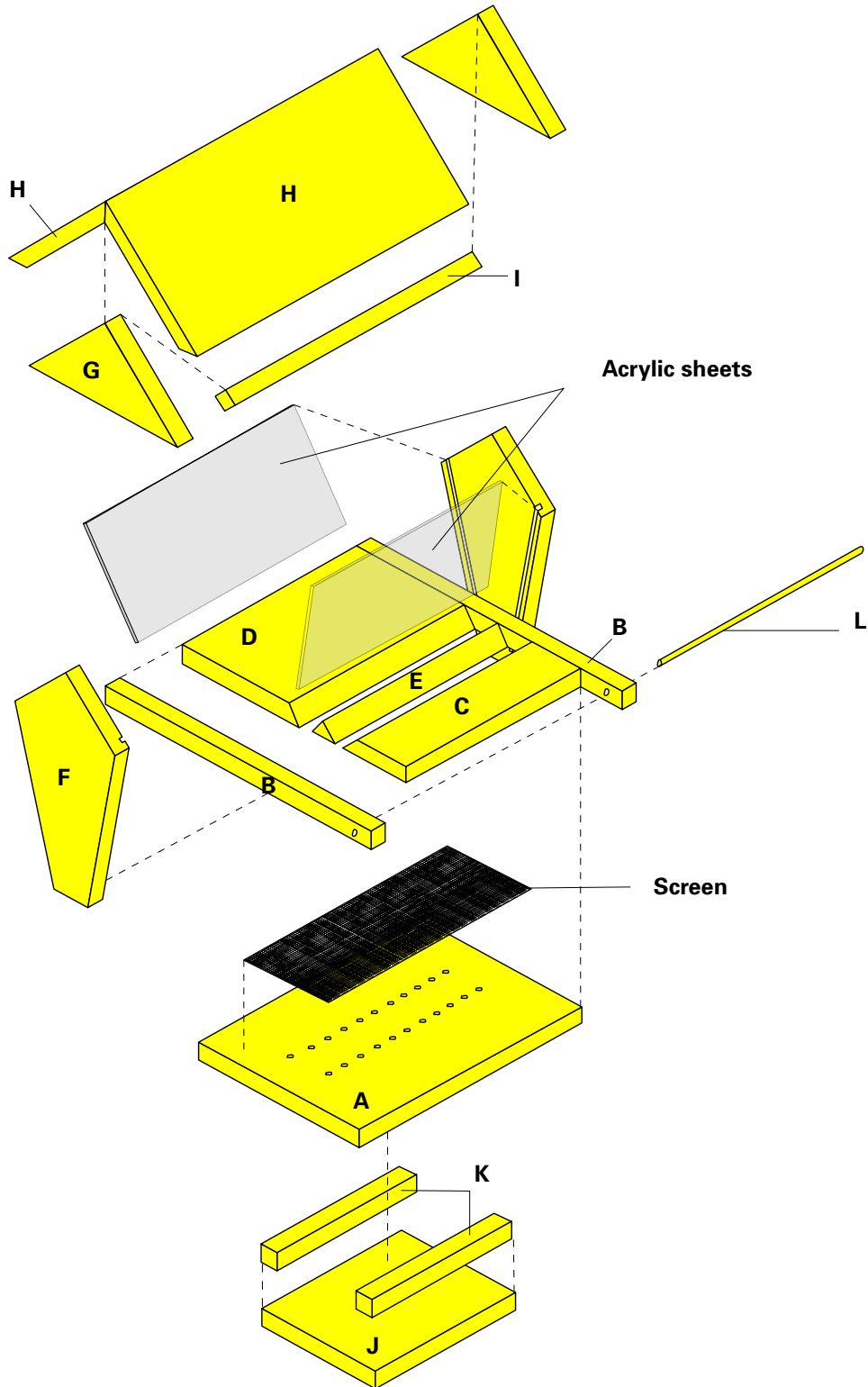

Bird Feeder



Finished view

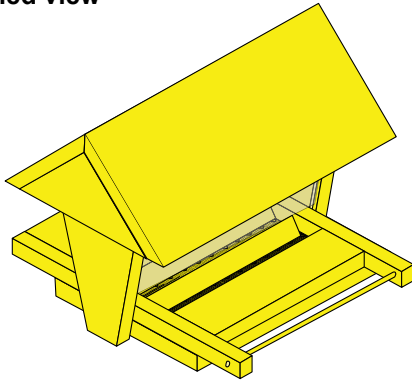

Roof detail

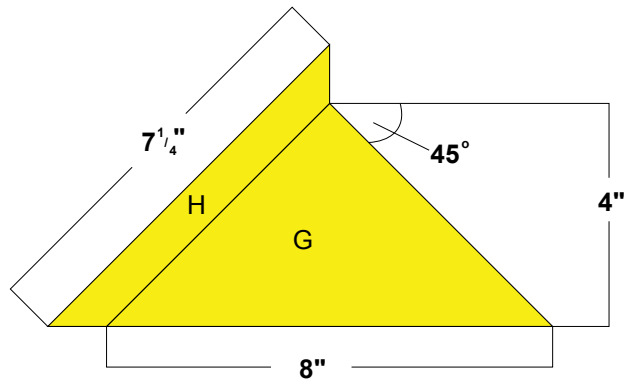

Hopper end detail

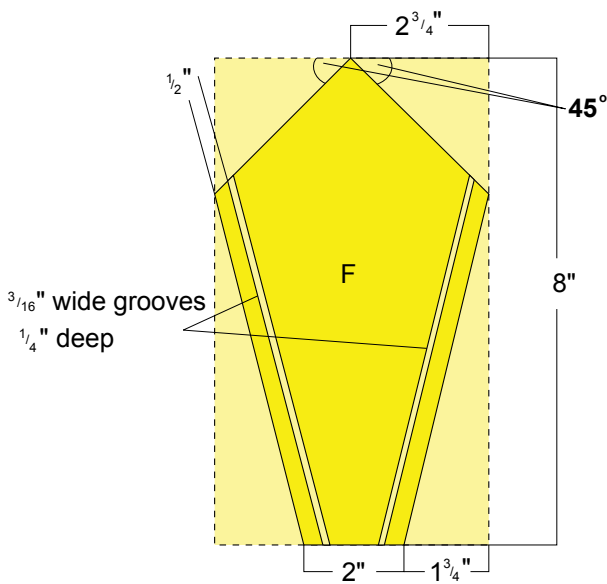

Bird Feeder

YellaWood
Pressure Treated Pine

BUILDING STEPS

- 01** Cut pieces A through E to the dimensions noted on the cut list. To make part D, you will have to cut 2 pieces of 1 x 8 at 11 ½" long and edge glue and clamp them together. Once the glue has set, trim to size on your table saw.



- 02** Mark two lines on the base (A) at 2 ¾" and 4 ¾" along the narrow edge and square them down along the length. Drill a series of ten ½" diameter holes along each line, spaced about 1" in from the ends and 1" apart (no need to be exact as long as they are all drilled on your two square lines).



- 03** Cut a piece of metal screen to 5" x 10" and place it over the holes you drilled in the base (A). Attach it with ⅜" galvanized staples.



- 04** With bottom (D) face down on your assembly table, measure 4" in from the long point of the beveled edge and square a line. Place the edge of the base (A) on that line, keeping ends flush with (D), and attach with glue and screws. Repeat the process with bottom (C), measuring 1 ½" from the beveled edge and placing the other end of (A) on that line.



- 05** Place bottom (E) between (D) and (C), keeping ends flush and an approximate ¾" gap between all beveled edges. Make sure the gaps line up with the drainage holes in base (A). Tack (E) to (A) with 1 ¼" brads from the top side, then flip over and drive screws from underneath (no glue on this step).



Bird Feeder

YellaWood
Pressure Treated Pine

BUILDING STEPS

06 Tack ends (B) in place with glue and 1 ¼" brads along the edges of your base/bottom assembly, keeping ends flush with part (D) and extending 2 ¾" beyond part (C). Carefully drill pilot holes and drive screws to permanently attach.



07 Cut remaining pieces, noting bevel and angle details on hopper ends (F) and roof components (G, H). To cut the grooves in hopper ends (F), set your table saw blade height at ¼" and set the fence at ½". Run all 4 grooves on both hopper ends, then bump the fence very slightly to about ⅞" and run them again, resulting in grooves about ⅜" wide. Line up center of hopper ends (F) with the peak of bottom (E) on both sides, keeping bottom edge of hopper (F) flush with bottom edge of ends (B). Attach with glue and screws.



08 Attach cross piece (I) between the peaks of hopper ends (F), with glue and 1 ¼" brads, keeping edges flush.



09 Cut acrylic sheets to size. If you can't have them cut to size, cut them yourself by running a sharp utility knife along a straightedge several times (10 or more) and snapping them along that line. For smaller cutoffs or to clean up a cut edge, you may need to break off pieces with a pair of pliers. Insert into grooves in hopper ends (F).



10 Attach roof tops (H) to roof ends (G) with glue and screws.



Bird Feeder

YellaWood
Pressure Treated Pine

- 11** Drill two $\frac{5}{16}$ " holes in end pieces (B), centered along the width and 1 $\frac{1}{4}$ " in from the end overhanging part (C). Put a small bit of glue in both holes, insert dowel and attach with $\frac{3}{4}$ " brads.



- 12** Attach spacers (K) to mounting base (J) with glue and 1 $\frac{1}{4}$ " brads. If you will be attaching this to a wooden post, screw the mounting base to the post first, then attach mounting base to the underside of base (A), with 2" screws, making sure that the spacers do not block drainage holes. Another method is to attach mounting base to bottom of base (A), then attach a pipe flange to the underside of the mounting base and screw the flange onto the top of a threaded pipe driven into the ground. Either way, your feeder is ready to sand, finish, fill and enjoy!



- 13** We recommend long lasting YellaWood Protector[®] semi-transparent stain and water repellent wood sealer, the only stain backed by the famous Yella Tag. Follow manufacturer's recommendations for application.



FASTENER AND HARDWARE INFORMATION SHEET

YellaWood®
Pressure Treated Pine

For interior or exterior applications

Use fasteners and hardware that are in compliance with the manufacturer's recommendations and the building codes for their intended use. As with any good design and construction practices, treated wood should not be used in applications where trapped moisture or water can occur. Where design and/or actual conditions allow for constant, repetitive or long periods of wet conditions, only stainless steel fasteners should be used.

For exterior applications

The following minimum galvanization levels may be used for connectors, joist hangers, fasteners and other hardware that are placed in direct contact with exterior applications of micronized copper treated wood:

- **Fasteners** - nails, screws, etc.
ASTM – A 153 (1 oz/ft²)
- **Hardware** - connectors, joist hangers, etc.
ASTM – A 653 G90 (0.90 oz/ft²)

The effects of other building materials within a given assembly, along with environmental factors, should also be considered when selecting the appropriate hardware and fasteners to use for a given project containing treated wood.

Stainless Steel fasteners and hardware are required for Permanent Wood Foundations below grade and are recommended for use with treated wood in other severe exterior applications such as swimming pools, salt water exposure, etc. - Type 304 and 316 are recommended grades to use.

Aluminum building products may be placed in direct contact with YellaWood® brand products used for interior uses and above ground exterior applications such as decks, fencing, and landscaping projects. Examples of aluminum products include siding, roofing, gutters, door and window trim, flashing, nails, fasteners and other hardware connectors. However, direct contact of treated products and aluminum building products should be limited to code-compliant construction applications that provide proper water drainage and do not allow the wood to be exposed to standing water or water immersion.

We recommend you contact the aluminum building products manufacturer for its recommendations regarding use of its aluminum products in contact with treated wood in ground contact applications or when exposed to salt water, brackish water, or chlorinated water, such as swimming pools or hot tubs.

Also check with the aluminum building products manufacturer regarding compatibility with other chemicals and cleaning agents and the use of their aluminum products in commercial, industrial, and specialty applications such as boat construction.

YellaWood® brand pressure treated products are treated with preservatives (the "Preservatives") and preservative methods and technologies of unrelated third parties. For details regarding the Preservatives, methods, and technologies used by Great Southern Wood Preserving, Incorporated, see www.yellowood.com/preservative or write us at P.O. Box 610, Abbeville, AL 36310. Ask dealer for warranty details. For warranty or for important handling and other information concerning our products including the appropriate Safety Data Sheet (SDS), please visit us at www.yellowood.com/warranties or write us at P.O. Box 610, Abbeville, AL 36310. YellaWood®, YellaWood Protector® and the yellow tag are federally registered trademarks of Great Southern Wood Preserving, Incorporated.

Great Southern Wood Preserving, Incorporated makes no warranties expressed or implied as to the fitness for a particular purpose of this plan.

IMPORTANT INFORMATION

YellaWood®
Pressure Treated Pine

- Consult the end tag to determine which preservative or preservative system was used in the treatment of that particular product. YellaWood® brand products may be used in direct contact with aluminum building products when limited to code-compliant construction applications that provide proper water drainage and do not allow the wood to be exposed to standing water or water immersion.
- Use fasteners and other hardware that are in compliance with building codes for the intended use.
- Do not burn preserved wood.
- Wear a dust mask and goggles when cutting or sanding wood.
- Wear gloves when working with wood.
- Some preservative may migrate from the treated wood into soil/water or may dislodge from the treated wood surface upon contact with skin.
- Wash exposed skin areas thoroughly.
- All sawdust and construction debris should be cleaned up and disposed of after construction.
- Wash work clothes separately from other household clothing before reuse.
- Preserved wood should not be used where it may come into direct or indirect contact with drinking water, except for uses involving incidental contact such as fresh water docks and bridges.
- Do not use preserved wood under circumstances when the preservative may become a component of food, animal feed or beehives.
- Do not use preserved wood as mulch.
- Only preserved wood that is visibly clean and free of surface residue should be used.
- If the wood is to be used in an interior application and becomes wet during construction, it should be allowed to dry before being covered or enclosed.
- If you desire to apply a paint, stain, clear water repellent or other finish to your preservative-treated wood, we recommend following the manufacturer's instructions and label of the finishing product. Before you start, we recommend you apply the finishing product to a small exposed test area before finishing the entire project to ensure it provides the intended result before proceeding.
- Mold growth can and does occur on the surface of many products, including untreated and treated wood, during prolonged surface exposure to excessive moisture conditions. To remove mold from the treated wood surface, wood should be allowed to dry. Typically, mild soap and water can be used to remove remaining surface mold. For more information visit www.epa.gov.
- Projects should be designed and installed in accordance with federal, state and local building codes and ordinances governing construction in your area, and in accordance with the National Design Specifications (NDS) and the Wood Handbook.

Disposal Recommendations:

Preserved wood may be disposed of in landfills or burned in commercial or industrial incinerators or boilers in accordance with federal, state and local regulations.